

NOTES:

- 1) ALL DIMENSIONS ARE IN INCHES
- 2) RECOMMENDED MATERIAL IS .75" MDF
- 3) SUBWOOFER CUTOUT DIAMETER, OUTER DIAMETER, AND MOUNTING DEPTH ARE BASED ON PUBLISHED MANUFACTURER VALUES. THE BUILDER OF THIS ENCLOSURE MUST VERIFY VALUES BY MEASURING THE ACTUAL SUBWOOFER BEFORE CUTTING MATERIAL. C.A.F. IS NOT RESPONSIBLE FOR INCORRECT SPEAKER DIMENSIONS WITHIN THIS PRINT PACK
- 4) VERIFY FIT WITHIN VEHICLE BY BUILDING REAR, BOTTOM, AND SIDE OF THE ENCLOSURE BEFORE FINAL ASSEMBLY
- 5) IT IS THE RESPONSIBILITY OF THE INSTALLER OF THIS ENCLOSURE TO PROPERLY MOUNT AND SECURE THE ENCLOSURE WITHIN THE VEHICLE TO AVOID INJURY OR HARM TO PERSON OR PROPERTY IN ANY EVENT.

# SAMPLE!

THIS SAMPLE DOCUMENT IS MADE TO RANDOM VALUES AT A RANDOM TUNING.  
DO NOT USE.

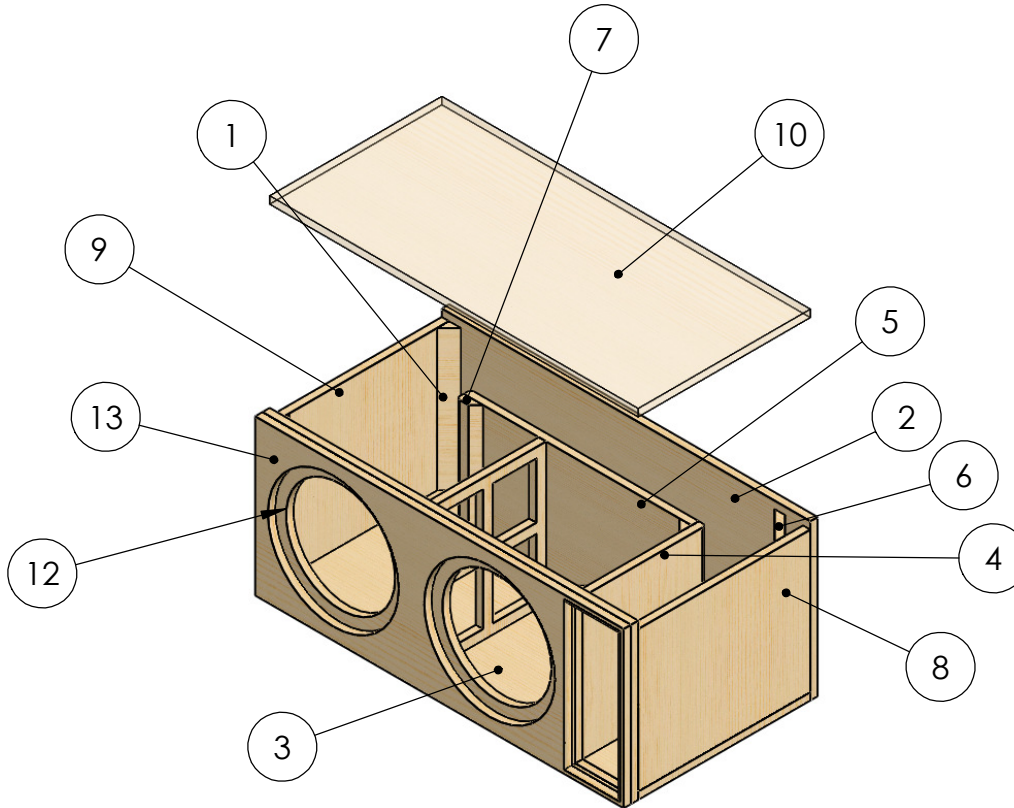

ITEM NO.	PART NUMBER	Default/ QTY.
1	2NSW_45	4
2	2NSW_Back	1
3	2NSW_Bottom	1
4	2NSW_Port1	1
5	2NSW_Port2	1
6	2NSW_Port45	1
7	2NSW_PortEndBrace	1
8	2NSW_Side1	1
9	2NSW_Side2	1
10	2NSW_Top	1
11	2NSW_FaceBrace	1
12	2NSW_Front1	1
13	2NSW_Front2	1

## CARAUDIO™

### FABRICATION.COM

MASTER CAR AUDIO | DESIGN, BUILD, INSTALL

DRAWN BY:	
SUBWOOFER SIZE:	SAMPLE SIZE
SUBWOOFER QTY:	2
SUBWOOFER MODEL:	SAMPLE SUBWOOFER
BOX FREQ / VOLUME:	XX / X.XX

**PROPRIETARY AND CONFIDENTIAL**  
THE INFORMATION CONTAINED IN THIS DRAWING IS THE SOLE PROPERTY OF "CAR AUDIO FABRICATION". ANY REPRODUCTION IN PART OR AS A WHOLE WITHOUT THE WRITTEN PERMISSION OF "CAR AUDIO FABRICATION" IS PROHIBITED.

BOX DESIGN:		
SAMPLE		
SIZE	PIECE: 2NSW	REV 000
SCALE: 1:14		SHEET 1 OF 16

# SAMPLE!

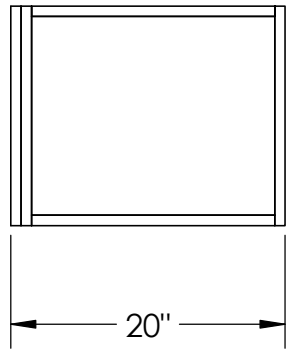
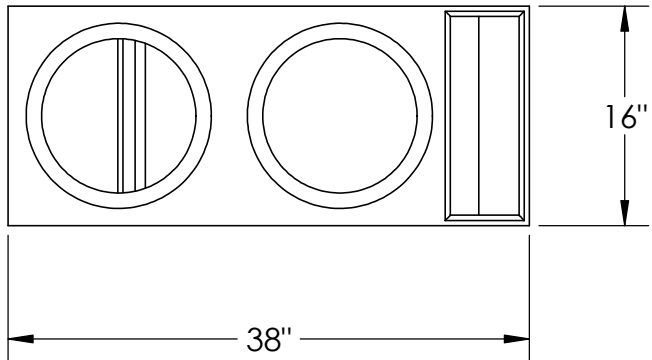
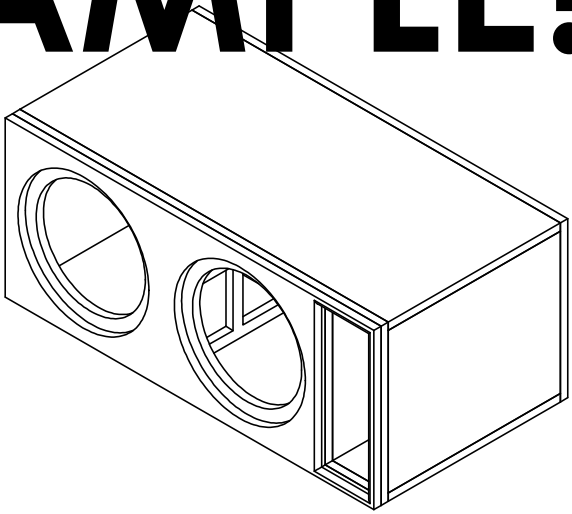
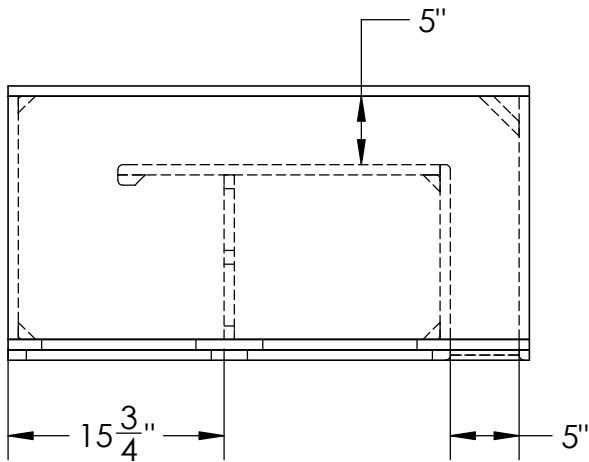

MASTER CAR AUDIO | DESIGN, BUILD, INSTALL

DRAWN BY:	
SUBWOOFER SIZE:	SAMPLE SIZE
SUBWOOFER QTY:	2
SUBWOOFER MODEL:	SAMPLE SUBWOOFER
BOX FREQ / VOLUME:	XX / X.XX

BOX DESIGN:		
SAMPLE		
SIZE	PIECE:	REV
A	2NSW	000

**PROPRIETARY AND CONFIDENTIAL**  
THE INFORMATION CONTAINED IN THIS DRAWING IS THE SOLE PROPERTY OF "CAR AUDIO FABRICATION". ANY REPRODUCTION IN PART OR AS A WHOLE WITHOUT THE WRITTEN PERMISSION OF "CAR AUDIO FABRICATION" IS PROHIBITED.

SCALE: 1:14		SHEET 2 OF 16
-------------	--	---------------

# SAMPLE!

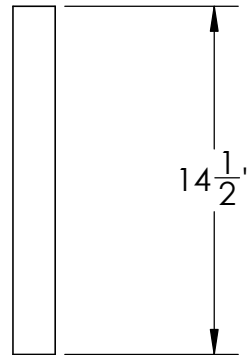
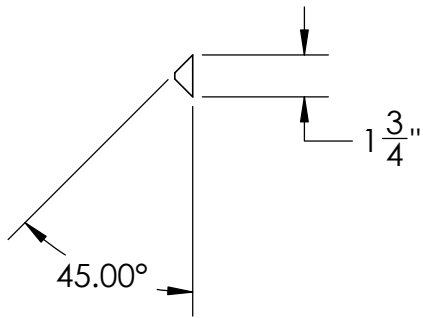

DRAWN BY:	
SUBWOOFER SIZE:	
SUBWOOFER QTY:	0
SUBWOOFER MODEL:	
BOX FREQ / VOLUME:	

BOX DESIGN:

**PROPRIETARY AND CONFIDENTIAL**  
THE INFORMATION CONTAINED IN THIS DRAWING IS THE SOLE PROPERTY OF "CAR AUDIO FABRICATION". ANY REPRODUCTION IN PART OR AS A WHOLE WITHOUT THE WRITTEN PERMISSION OF "CAR AUDIO FABRICATION" IS PROHIBITED.

SIZE <b>A</b>	PIECE: 2NSW_45	REV
SCALE: 1:8		SHEET 3 OF 16

# SAMPLE!

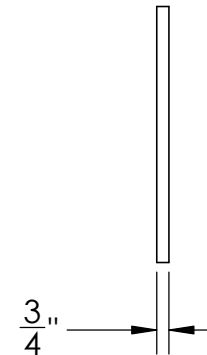
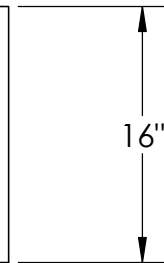
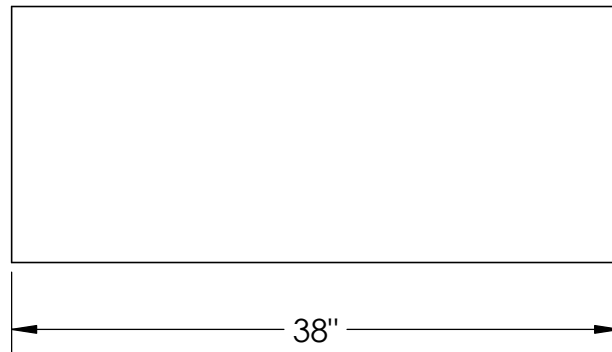
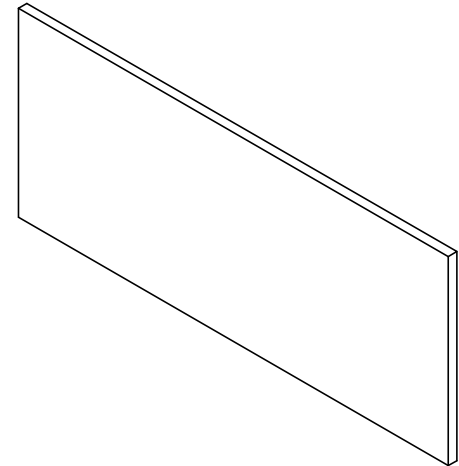
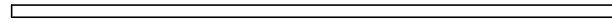

DRAWN BY:	
SUBWOOFER SIZE:	
SUBWOOFER QTY:	0
SUBWOOFER MODEL:	
BOX FREQ / VOLUME:	

BOX DESIGN:		
SIZE	PIECE:	REV
<b>A</b>	2NSW_Back	

**PROPRIETARY AND CONFIDENTIAL**  
 THE INFORMATION CONTAINED IN THIS DRAWING IS THE SOLE PROPERTY OF "CAR AUDIO FABRICATION". ANY REPRODUCTION IN PART OR AS A WHOLE WITHOUT THE WRITTEN PERMISSION OF "CAR AUDIO FABRICATION" IS PROHIBITED.

SCALE: 1:12	SHEET 4 OF 16
-------------	---------------

# SAMPLE!

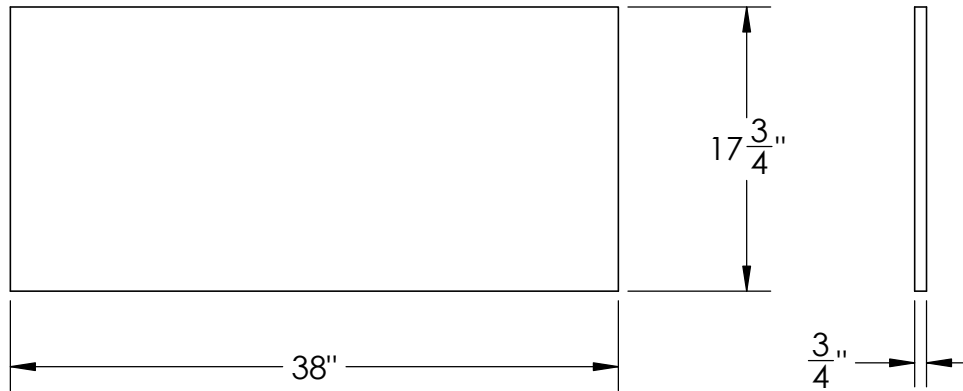
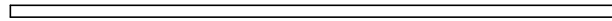
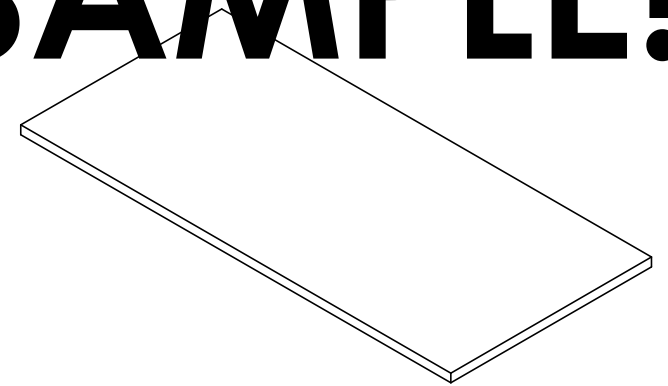

DRAWN BY:	
SUBWOOFER SIZE:	
SUBWOOFER QTY:	0
SUBWOOFER MODEL:	
BOX FREQ / VOLUME:	

BOX DESIGN:		
SIZE <b>A</b>	PIECE: 2NSW_Bottom	REV
SCALE: 1:12		SHEET 5 OF 16

**PROPRIETARY AND CONFIDENTIAL**  
THE INFORMATION CONTAINED IN THIS DRAWING IS THE SOLE PROPERTY OF "CAR AUDIO FABRICATION". ANY REPRODUCTION IN PART OR AS A WHOLE WITHOUT THE WRITTEN PERMISSION OF "CAR AUDIO FABRICATION" IS PROHIBITED.

# SAMPLE!

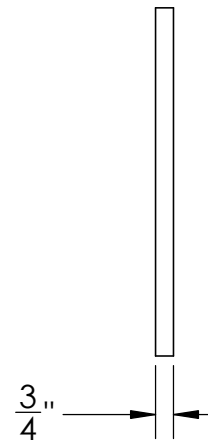
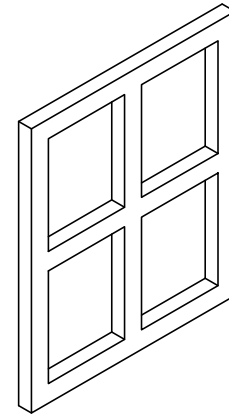
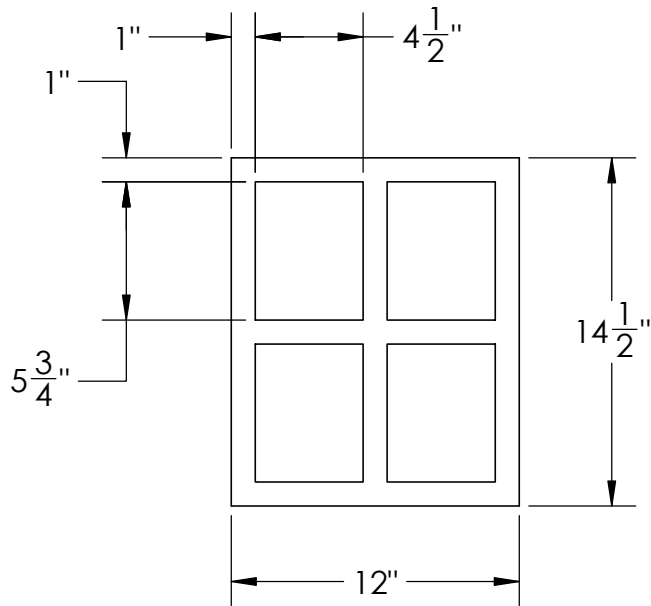

DRAWN BY:		BOX DESIGN:		
SUBWOOFER SIZE:				
SUBWOOFER QTY:	0			
SUBWOOFER MODEL:				
BOX FREQ / VOLUME:				
<b>PROPRIETARY AND CONFIDENTIAL</b> THE INFORMATION CONTAINED IN THIS DRAWING IS THE SOLE PROPERTY OF "CAR AUDIO FABRICATION". ANY REPRODUCTION IN PART OR AS A WHOLE WITHOUT THE WRITTEN PERMISSION OF "CAR AUDIO FABRICATION" IS PROHIBITED.		SIZE <b>A</b>	PIECE: 2NSW_FaceBrace	REV
		SCALE: 1:12	SHEET 6 OF 16	

NOTE: SUBWOOFER CUTOUT DIAMETER, OUTER DIAMETER, AND MOUNTING DEPTH ARE BASED ON PUBLISHED MANUFACTURER VALUES. THE BUILDER OF THIS ENCLOSURE MUST VERIFY VALUES BY MEASURING THE ACTUAL SUBWOOFER BEFORE CUTTING MATERIAL. C.A.F. IS NOT RESPONSIBLE FOR INCORRECT SPEAKER DIMENSIONS WITHIN THIS PRINT PACK

# SAMPLE!

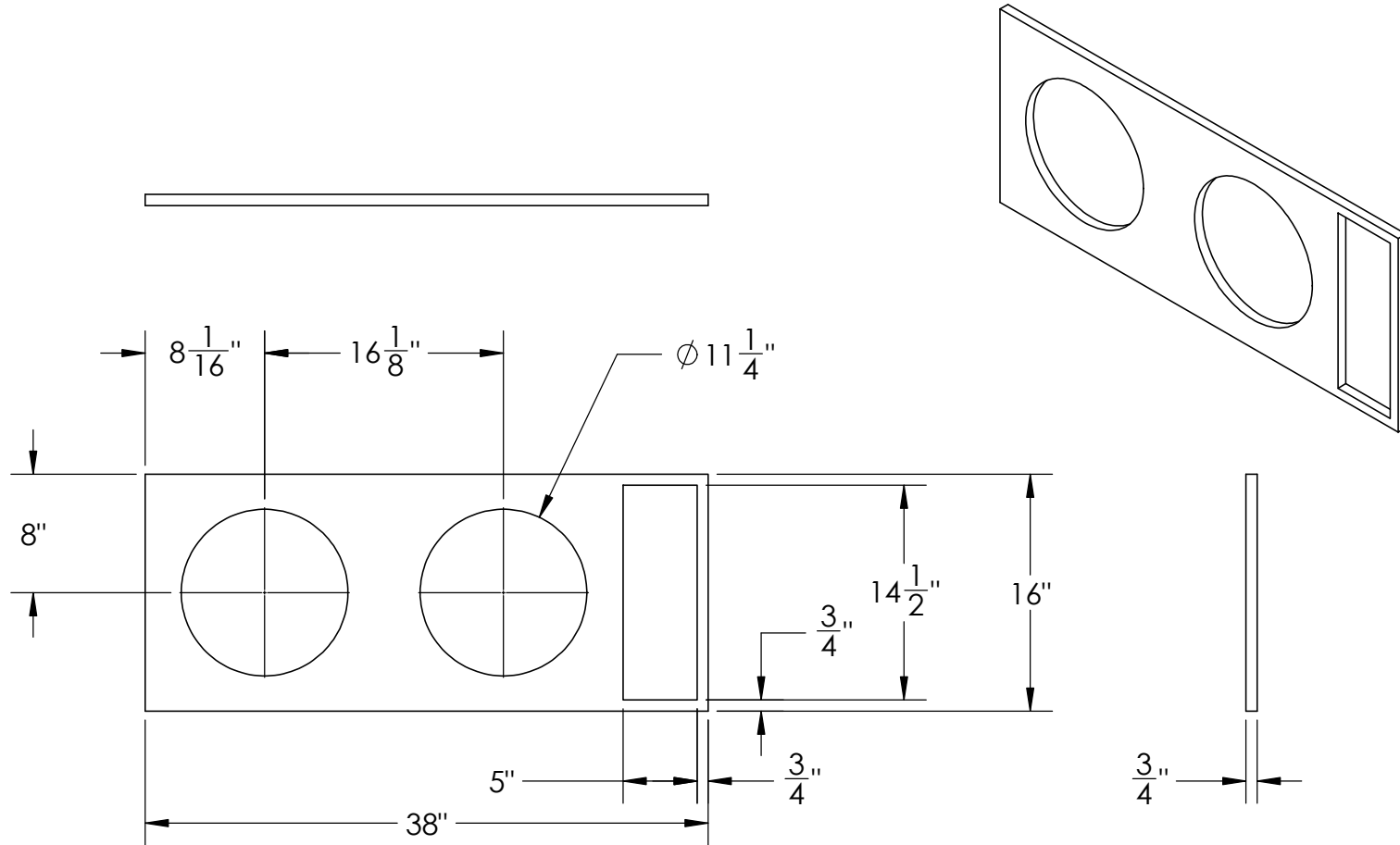

DRAWN BY:	
SUBWOOFER SIZE:	
SUBWOOFER QTY:	0
SUBWOOFER MODEL:	
BOX FREQ / VOLUME:	

BOX DESIGN:		
SIZE	PIECE:	REV
<b>A</b>	2NSW_Front1	
SCALE: 1:12		SHEET 7 OF 16

**PROPRIETARY AND CONFIDENTIAL**  
 THE INFORMATION CONTAINED IN THIS DRAWING IS THE SOLE PROPERTY OF "CAR AUDIO FABRICATION". ANY REPRODUCTION IN PART OR AS A WHOLE WITHOUT THE WRITTEN PERMISSION OF "CAR AUDIO FABRICATION" IS PROHIBITED.

NOTE: SUBWOOFER CUTOUT DIAMETER, OUTER DIAMETER, AND MOUNTING DEPTH ARE BASED ON PUBLISHED MANUFACTURER VALUES. THE BUILDER OF THIS ENCLOSURE MUST VERIFY VALUES BY MEASURING THE ACTUAL SUBWOOFER BEFORE CUTTING MATERIAL. C.A.F. IS NOT RESPONSIBLE FOR INCORRECT SPEAKER DIMENSIONS WITHIN THIS PRINT PACK

# SAMPLE!

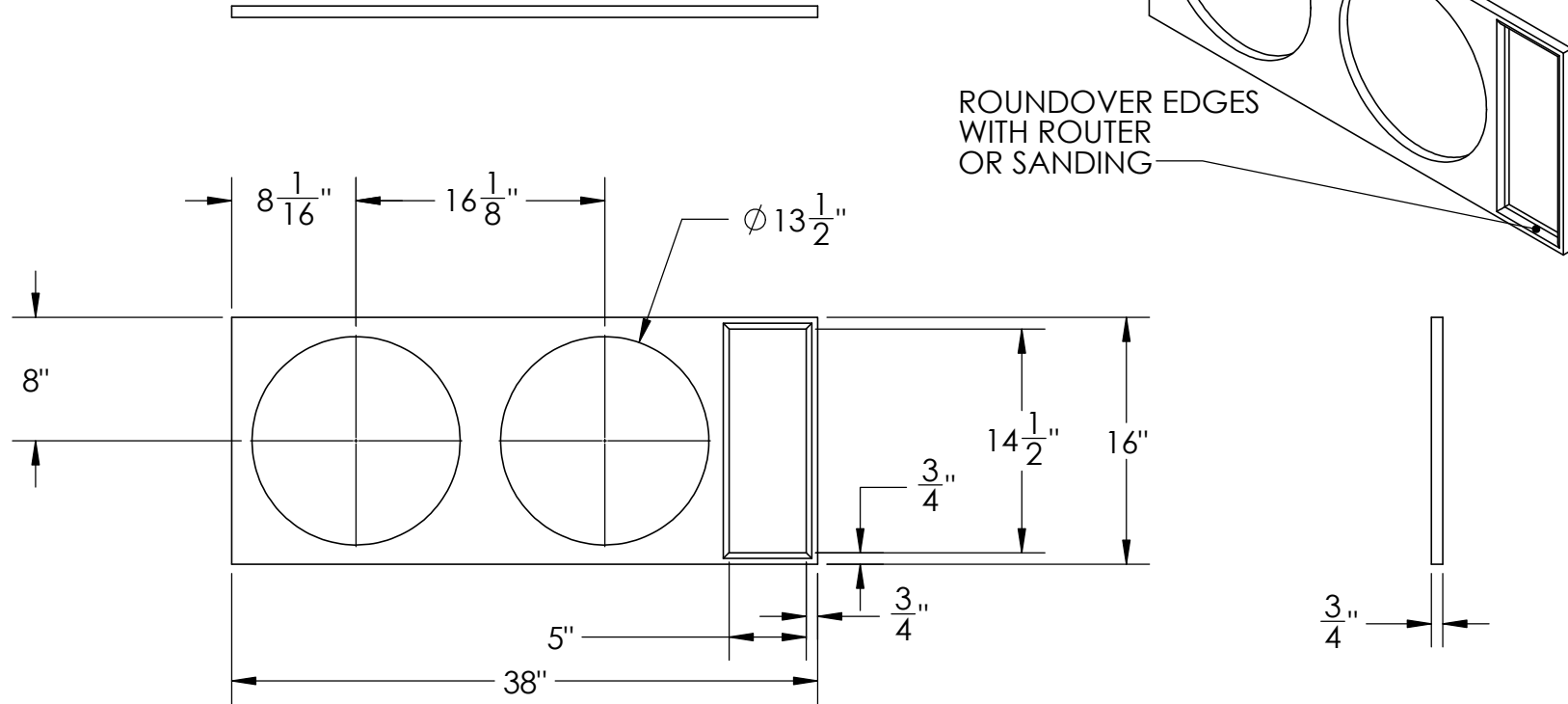

DRAWN BY:		BOX DESIGN:		
SUBWOOFER SIZE:				
SUBWOOFER QTY:	0			
SUBWOOFER MODEL:				
BOX FREQ / VOLUME:				
<b>PROPRIETARY AND CONFIDENTIAL</b> THE INFORMATION CONTAINED IN THIS DRAWING IS THE SOLE PROPERTY OF "CAR AUDIO FABRICATION". ANY REPRODUCTION IN PART OR AS A WHOLE WITHOUT THE WRITTEN PERMISSION OF "CAR AUDIO FABRICATION" IS PROHIBITED.		SIZE	PIECE:	REV
		<b>A</b>	2NSW_Front2	
		SCALE: 1:12	SHEET 8 OF 16	



# SAMPLE!

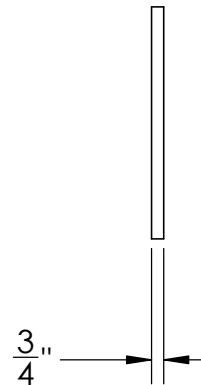
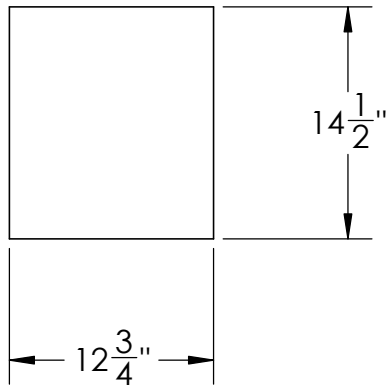
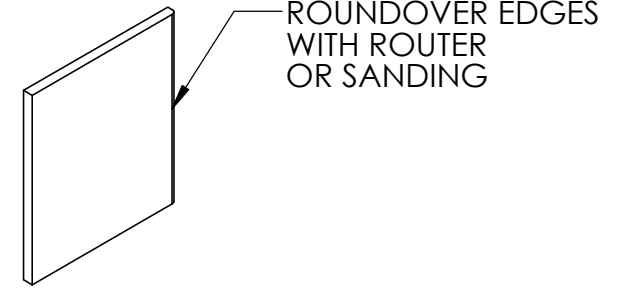
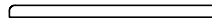

DRAWN BY:	
SUBWOOFER SIZE:	
SUBWOOFER QTY:	0
SUBWOOFER MODEL:	
BOX FREQ / VOLUME:	

BOX DESIGN:		
SIZE	PIECE:	REV
A	2NSW_Port1	

**PROPRIETARY AND CONFIDENTIAL**  
 THE INFORMATION CONTAINED IN THIS DRAWING IS THE SOLE PROPERTY OF "CAR AUDIO FABRICATION". ANY REPRODUCTION IN PART OR AS A WHOLE WITHOUT THE WRITTEN PERMISSION OF "CAR AUDIO FABRICATION" IS PROHIBITED.

SCALE: 1:12	SHEET 9 OF 16
-------------	---------------

# SAMPLE!

ROUNDOVER EDGES  
WITH ROUTER  
OR SANDING

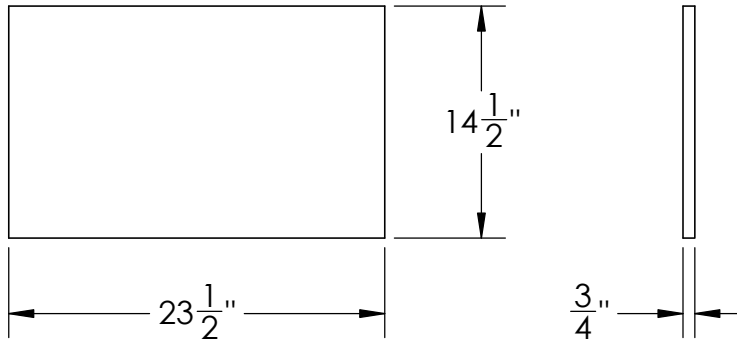
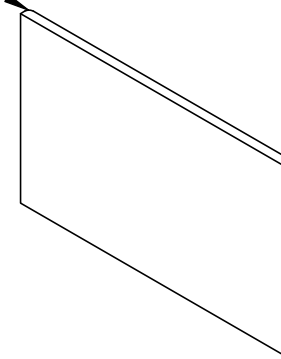
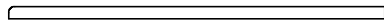

DRAWN BY:	
SUBWOOFER SIZE:	
SUBWOOFER QTY:	0
SUBWOOFER MODEL:	
BOX FREQ / VOLUME:	

BOX DESIGN:		
SIZE	PIECE:	REV
<b>A</b>	2NSW_Port2	
SCALE: 1:12		SHEET 10 OF 16

**PROPRIETARY AND CONFIDENTIAL**  
THE INFORMATION CONTAINED IN THIS DRAWING IS THE SOLE PROPERTY OF "CAR AUDIO FABRICATION". ANY REPRODUCTION IN PART OR AS A WHOLE WITHOUT THE WRITTEN PERMISSION OF "CAR AUDIO FABRICATION" IS PROHIBITED.

# SAMPLE!

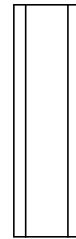
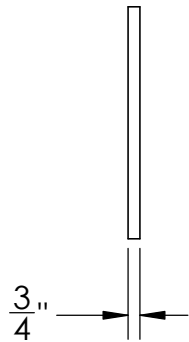
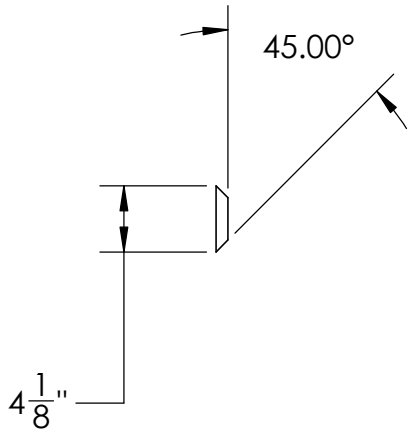

DRAWN BY:		BOX DESIGN:	
SUBWOOFER SIZE:			
SUBWOOFER QTY:			
SUBWOOFER MODEL:			
BOX FREQ / VOLUME:			
<b>PROPRIETARY AND CONFIDENTIAL</b> THE INFORMATION CONTAINED IN THIS DRAWING IS THE SOLE PROPERTY OF "CAR AUDIO FABRICATION". ANY REPRODUCTION IN PART OR AS A WHOLE WITHOUT THE WRITTEN PERMISSION OF "CAR AUDIO FABRICATION" IS PROHIBITED.	SIZE <b>A</b>	PIECE: 2NSW_Port45	REV
		SCALE: 1:12	SHEET 11 OF 16

# SAMPLE!

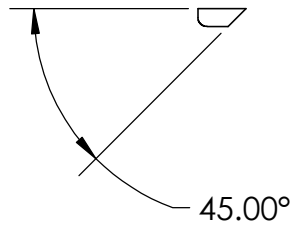

ROUND OVER EDGES  
WITH ROUTER  
OR SANDING

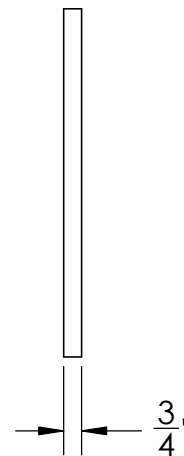
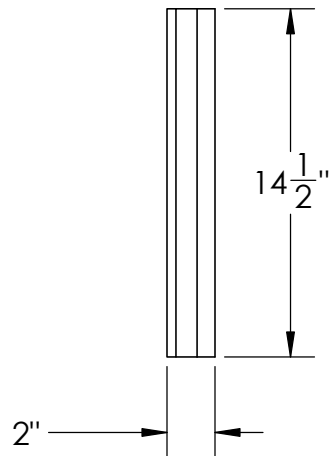
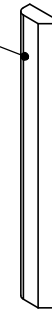

DRAWN BY:	
SUBWOOFER SIZE:	
SUBWOOFER QTY:	0
SUBWOOFER MODEL:	
BOX FREQ / VOLUME:	

BOX DESIGN:		
SIZE	PIECE:	REV
<b>A</b>	2NSW_PortEndBrace	

**PROPRIETARY AND CONFIDENTIAL**  
THE INFORMATION CONTAINED IN THIS DRAWING IS THE SOLE PROPERTY OF "CAR AUDIO FABRICATION". ANY REPRODUCTION IN PART OR AS A WHOLE WITHOUT THE WRITTEN PERMISSION OF "CAR AUDIO FABRICATION" IS PROHIBITED.

SCALE: 1:12	SHEET 12 OF 16
-------------	----------------

# SAMPLE!

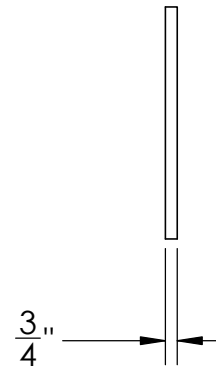
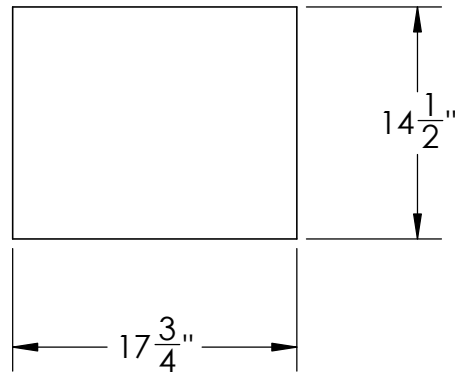
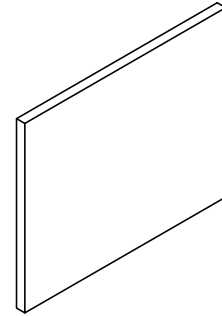
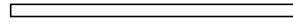

DRAWN BY:	
SUBWOOFER SIZE:	
SUBWOOFER QTY:	0
SUBWOOFER MODEL:	
BOX FREQ / VOLUME:	

BOX DESIGN:		
SIZE <b>A</b>	PIECE: 2NSW_Side1	REV
SCALE: 1:12		SHEET 13 OF 16

**PROPRIETARY AND CONFIDENTIAL**  
THE INFORMATION CONTAINED IN THIS DRAWING IS THE SOLE PROPERTY OF "CAR AUDIO FABRICATION". ANY REPRODUCTION IN PART OR AS A WHOLE WITHOUT THE WRITTEN PERMISSION OF "CAR AUDIO FABRICATION" IS PROHIBITED.

# SAMPLE!

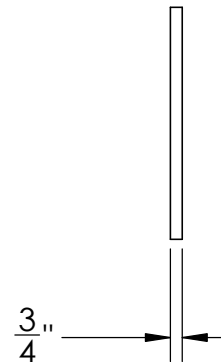
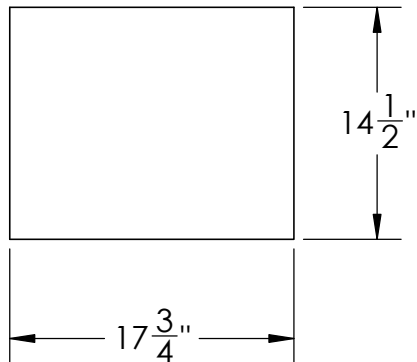
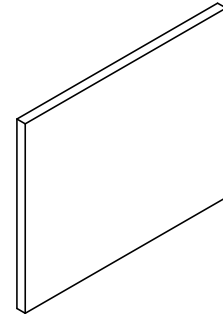
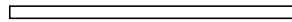

DRAWN BY:	
SUBWOOFER SIZE:	
SUBWOOFER QTY:	0
SUBWOOFER MODEL:	
BOX FREQ / VOLUME:	

BOX DESIGN:		
SIZE	PIECE:	REV
<b>A</b>	2NSW_Side2	
SCALE: 1:12		SHEET 14 OF 16

**PROPRIETARY AND CONFIDENTIAL**  
 THE INFORMATION CONTAINED IN THIS DRAWING IS THE SOLE PROPERTY OF "CAR AUDIO FABRICATION". ANY REPRODUCTION IN PART OR AS A WHOLE WITHOUT THE WRITTEN PERMISSION OF "CAR AUDIO FABRICATION" IS PROHIBITED.

# SAMPLE!

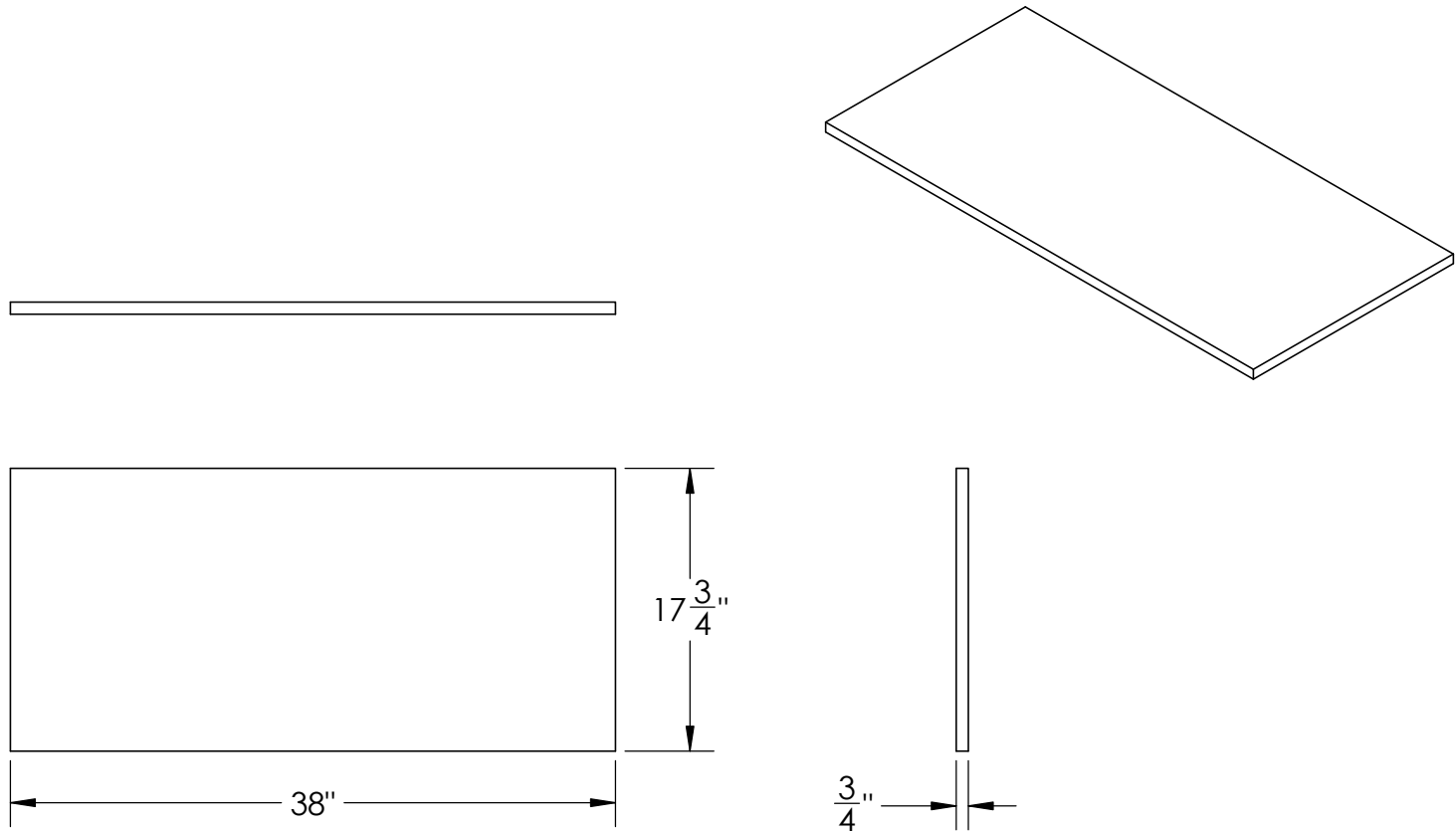

DRAWN BY:	
SUBWOOFER SIZE:	
SUBWOOFER QTY:	0
SUBWOOFER MODEL:	
BOX FREQ / VOLUME:	

BOX DESIGN:		
SIZE	PIECE:	REV
<b>A</b>	2NSW_Top	
SCALE: 1:12		SHEET 15 OF 16

**PROPRIETARY AND CONFIDENTIAL**  
 THE INFORMATION CONTAINED IN THIS DRAWING IS THE SOLE PROPERTY OF "CAR AUDIO FABRICATION". ANY REPRODUCTION IN PART OR AS A WHOLE WITHOUT THE WRITTEN PERMISSION OF "CAR AUDIO FABRICATION" IS PROHIBITED.

# SAMPLE!



DRAWN BY:		BOX DESIGN:		
SUBWOOFER SIZE:				
SUBWOOFER QTY:				
SUBWOOFER MODEL:				
BOX FREQ / VOLUME:				
<b>PROPRIETARY AND CONFIDENTIAL</b> THE INFORMATION CONTAINED IN THIS DRAWING IS THE SOLE PROPERTY OF "CAR AUDIO FABRICATION". ANY REPRODUCTION IN PART OR AS A WHOLE WITHOUT THE WRITTEN PERMISSION OF "CAR AUDIO FABRICATION" IS PROHIBITED.		SIZE <b>A</b>	PIECE:	REV
		SCALE: 1:10		SHEET 16 OF 16

5



4

3

2

1